

USER GUIDE

D77T-V

A decorative graphic on the left side of the page consisting of several overlapping circles in various shades of gray, with three small dots of varying sizes positioned to the right of the circles.

SAGEMCOM

TABLE OF CONTENTS

4	INFORMATION
4	Preface
4	Safety information
5	Application information
5	Environment
6	Setting up/range
7	SET-UP
7	D77 box contents
8	Presenting the base unit
9	Presenting the handset
10	The Navigator
11	Rapid access to the answering machine messages
11	Screen
12	Base unit connection
13	Inserting batteries in the handset
14	Battery function duration
14	Longevity of the battery
14	Battery charging status
14	Switching the handset on and off
14	Out of range
15	BLOCK DIAGRAM
16	MAKING TELEPHONE CALLS
16	Making an external call
16	Answering a call
16	Making an internal call
16	CLI (Caller Line ID) function
17	Managing calls whilst communication is underway
17	Call management
18	Locking the handset keypad
18	Using in hands-free mode
19	Setting the volume
19	Secret mode
20	PHONEBOOK
20	Adding a phonebook entry
20	Viewing a phonebook entry
21	Editing a phonebook entry
21	Deleting a phonebook entry
21	Deleting the entire phonebook
22	DATE AND TIME
22	Set the time and date

TABLE OF CONTENTS

23	CUSTOMISATION
23	Setting the melody and handset volume for an external call
23	Customising the name of the handset
23	Activating/deactivating automatic pick-up
23	Activating/deactivating automatic Hang-up
24	Setting the menu language
24	Setting the base unit melody and volume
25	ADVANCED SETTINGS
25	Setting the flash time
25	Registering a new handset
26	Removing a handset
26	Changing your PIN code
27	Resetting the handset and the base unit default settings
28	CALL LOG
28	To display the list of calls made
28	Removing numbers from the list of calls
28	Storing a caller's details in the phonebook
29	ANSWERING MACHINE (D77V only)
29	Playing a message
30	Recording a memo
30	Selecting answer machine mode
32	Activating/deactivating the answering machine
32	TAM Settings
33	Remote control
37	TECHNICAL DATA
37	Condition on delivery
38	Features
39	WARRANTY
39	Terms and Conditions for United Kingdom & Ireland only

INFORMATION

Preface

Dear customer, congratulations on buying your SAGEMCOM DECT telephone and thank you for placing your confidence in us. This device has been manufactured with the utmost care. If you should have difficulties in operating it, we recommend that you consult this user manual.

You can also find information on the following site:

<http://www.sagemcom.com>

To operate the device safely and easily, please read the following sections carefully:

Safety information

- Do not install your DECT telephone in a damp environment, such as a bathroom, washroom, kitchen etc, and not within 1.50 metres of a source of water or outside. This device is designed for use in temperatures of between 5 °C and 45 °C.
- Only use the power unit supplied and connect it to the electricity mains in accordance with the installation instructions in this user manual and the details on the sticker regarding voltage, electrical current and frequency. As a precaution if there is a risk of danger, the power plug can be pulled out to disconnect the 230 volt power supply. Therefore the sockets should be near the device and easily accessible.
- This device is designed to be used for connecting to the public telephone network. If problems should arise, contact your nearest specialist dealer. Only use the telephone cable supplied.
- For safety reasons, never put the handset in the base station without the battery inserted or without the lid on the battery compartment as this could cause an electric shock.
- To avoid damaging your handset, only use certified rechargeable battery NiMH 2.4 V 600 mAh, never use non rechargeable battery. Insert the battery in the handset battery compartment respecting polarity.

The used battery must be disposed of in line with the recycling regulations in this user manual.

- Your DECT telephone has a range of approx. 50 metres indoors and up to 300 metres outdoors. The range can be affected by the proximity of metal objects, such as a television and electrical devices.
- Certain medical equipment and highly-sensitive machines or security systems may be affected by the transmission power of the telephone. In these cases we recommend adhering to the safety information.
- In regions greatly affected by electrical storms we recommend that you protect your telephone circuit with a special fixture for excess voltage.

INFORMATION



- You cannot make calls with the device if there is a power cut. Therefore keep another telephone at the ready in the event of an emergency.
- The CE label confirms that the product complies with the 1999/5/EC regulations of the European Union Parliament regarding wireless systems and telecommunications for user protection and for preventing electromagnetic interference. This ensures the allocated communication network is used properly and radio interference is avoided. The declaration of compliance may be looked up on the www.sagemcom.com website, section «Support» or can be obtained from the following address:
SAGEMCOM SAS
250, route de l'Empereur - 92500 Rueil-Malmaison - France

Application information

This telephone is to be used for transmitting voice messages via telephone networks. Any other use is not permitted and is considered unfit for the intended use.

Environment

Environmental protection and sustainable development is an important priority for SAGEMCOM. SAGEMCOM has a policy of using environmentally-friendly systems and makes environmental protection an essential part of the life-cycle of its products – from the manufacturing, to the installation, operation and disposal.

Packaging

The logo (green point) on the packaging means that a fee is paid to an authorised national organisation to improve packaging recycling and the recycling infrastructure. Follow the local sorting regulations for this type of waste product in order to improve recycling.

Batteries

If your product contains batteries, they must be disposed of at the designated collection points.

The product

The crossed out dustbin displayed on the product signifies that it belongs to the electrical and electronic equipment group. The European regulations request you to carry out your own selective recycling collection at:

- the sales outlet when you buy a similar new device.
- the collection points available in your area (recycling centres, sorting points, etc).



INFORMATION

This means you participate in the recycling and valorisation of used electric and electronic goods which would otherwise have a negative impact on the environment and health.

Setting up/range

Place the base station somewhere central and easily accessible where you want to use it.

Depending on the ambient conditions, the range can be up to approx. 300 metres outdoors. It has a range of up to 50 metres indoors depending on the space and structure of the building.

The structure of the building can cause signal shadows to occur. This can lead to short interruptions when speaking due to the weak signal.

The connection breaks up temporarily when there is insufficient field strength.

Place an anti-slip mat under the base station. The feet on the device do not usually leave any undesirable marks behind. Due to the variety of varnish and polish used on furniture, we cannot completely rule out the possibility that marks from the feet of the device are left on any surfaces.

SAGEMCOM does not accept any liability for this type of damage.

Operating the base station or charger outside or in areas exposed to frost is not permitted.

The recommended ambient temperature for operating the base station is $+5\text{ }^{\circ}\text{C} - +45\text{ }^{\circ}\text{C}$, the recommended relative air humidity is 20 % to 75 %.

The installation location must have a mains socket for 230 volts for the base station or the charger.



SET-UP

D77 box contents

Place the box in front of you, open it and make sure it contains the following items:

- one base,
- one handset,
- one battery compartment cover,
- one equipped power adapter,
- a rechargeable battery unit,
- one telephone line cord,
- this user guide.

In the case of purchasing a pack duo or trio, you will find in addition for each additional handset:

- a handset charger,
- an additional battery flap,
- A rechargeable battery unit.

SET-UP

Presenting the base unit

Your base is designed to fit into your family environment.

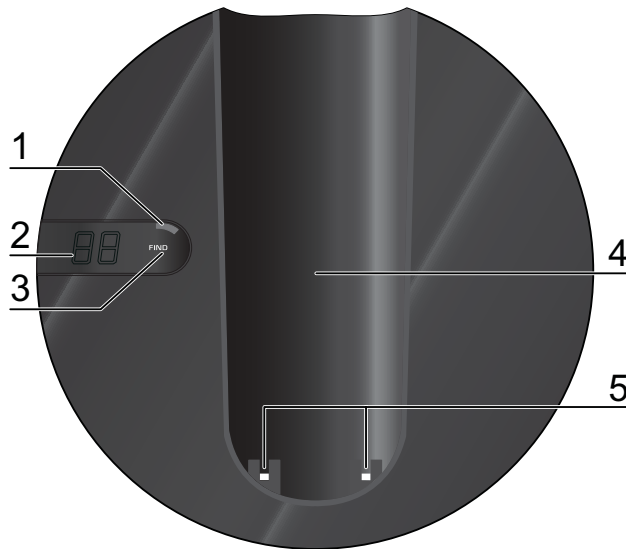

1. Flashing light on the base unit :
Red : handset charging
Green : line connection
Orange : line connection and the handset is charging.
Green + flashing slowly: base unit in paging mode.
Orange + flashing slowly: base unit in paging mode and the handset is charging.
Green + flashing quickly: base unit in pairing mode.
Orange + flashing quickly: base unit in pairing mode and the handset is charging.
Green + flashing slowly + flashing display :
Presence of new unread answering machine messages.
2. Display (model with answering machine only) :
Record mode (example **02**):
 - New messages : the display flashes indicating the number of unread messages.
 - No new messages : the display shows the number of read messages.Simple mode : **RD** is displayed.
Deactivated : **--** is displayed.
3. Base unit button :
Short press: searches for handsets (paging).
Long press: matching of handsets.
4. Location of the handset.
5. Base unit charging contacts.

SET-UP

Presenting the handset

You will appreciate the design and quality of the handset during conversations with your callers.

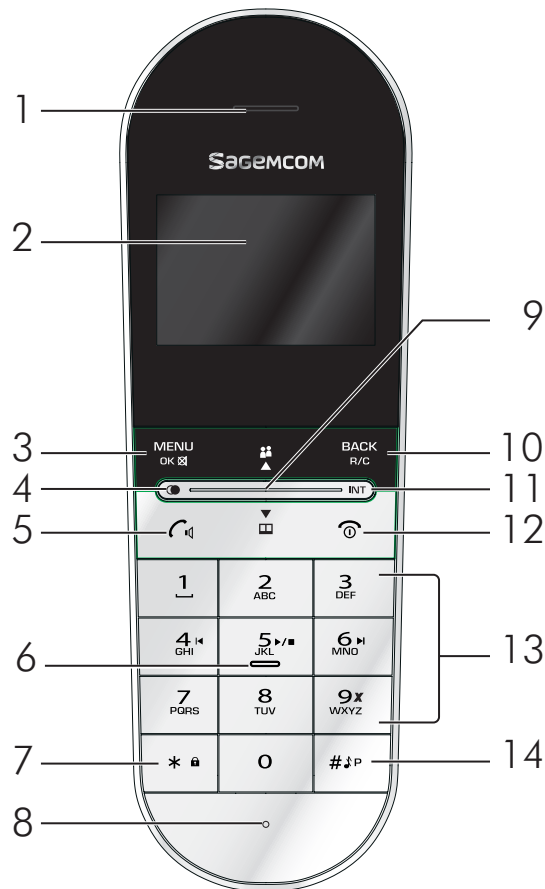

1. Speaker.
2. Display.
3. OK / Menu key / Secret mode key during communication (Secret).
4. Access list of calls made.
5. Phone pick-up / Speaker key.
6. Rapid access to your messages on the answering machine¹ ("Rapid access to the answering machine messages", page 11).
7. Lock/Unlock keypad.
8. Microphone.
9. Browser (refer to the next paragraph).
10. Return key / Cancelling an entry / R key.
11. Intercommunication (between handsets).
12. Hang up / Handset on/off.
13. Alphanumeric keypad.
14. Inserting a pause (long press) / Stopping the handset ring.

1. Model with answering machine only

SET-UP

The Navigator

This is the quick menu selection device.

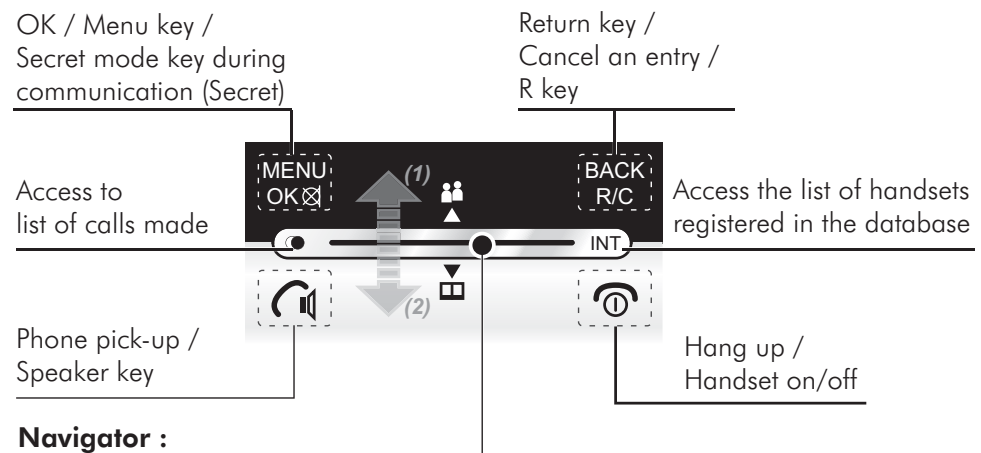

Navigator :

- Access to the list of calls received */
- Rapid access to the Phonebook */
- Browsing upwards in the menus **/
- Browsing downwards in the menus **/

- * **In standby mode** : the browser gives access to the list of calls received or the Phonebook :
 - to access the list of calls received, move the browser upwards (direction 1).
 - to access the Phonebook, move the browser downwards (direction 2).
- ** **In the menu** : the browser enables you to navigate upwards (direction 1) or downwards (direction 2). To do this, move the browser upwards ▲ or downwards ▼ .

SET-UP

Rapid access to the answering machine messages

You can view your answering machine messages from the standby screen by using the keyboard keys :

Long press on key 5 from the standby screen :	Start reading your messages. Stop play back.
Long press on key 6 while reading :	Go to the next message.
Long press on key 4 while reading :	Return to the previous message.
Long press on key 9 :	Delete the message being read.

Screen

Visual interface of your handset.

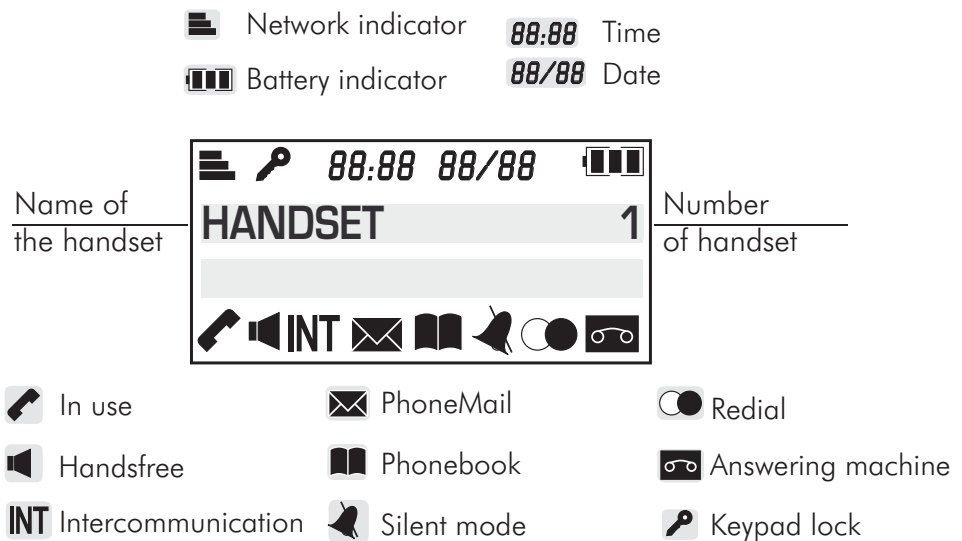

Operation using the menus and keys

Press the »Menu« key to access to the menus.

Select the menu of your choice by moving the browser up ▲ or down ▼ .

To enter the selected menu press the »OK« key.

SET-UP

To return to the previous menu press the »**BACK**« key.

In the menu, select the functions by moving the browser up ▲ or down ▼ and save the modified settings by pressing the »**OK**« key.

Once you have selected or set the function, you can return to the previous menu level (»**BACK**« key) or leave the menu (press »«).

Example: to change the handset melody for external calls:

1. Press the »**Menu**« key.
2. Select »**Personal Set**«, press the »**OK**« key.
3. Select »**Handset Tones**« by moving the browser up ▲ or down ▼, press the »**OK**« key.
4. Select »**Ring Melody**« by moving the browser up ▲ or down ▼, press the »**OK**« key.
5. Select the handset melody by moving the browser up ▲ or down ▼, press the »**OK**« key.
6. Press on the »« key to exit the menu.

Base unit connection

Before making connections read the safety instructions located at the start of this booklet.

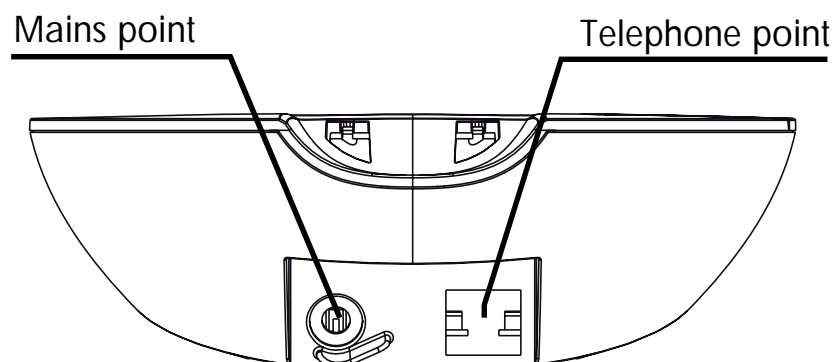

Insert the telephone point into its housing at the rear face of the base unit and connect the other end of the lead to the telephone wall point.

Connect the end of the mains power unit lead to the rear of the base unit and the mains power unit to a mains power supply. The base will emit an audible tone.

SET-UP

Pass the wires through the cable guide and place the base in its desired location.

Inserting batteries in the handset

- Turn over the handset and open the battery unit hatch.
- Insert the connector into its slot following the direction of the wires.

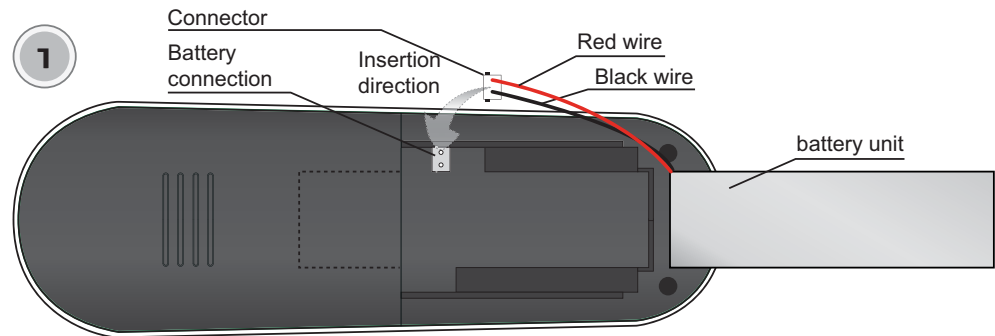

- Slide the battery unit into its slot.

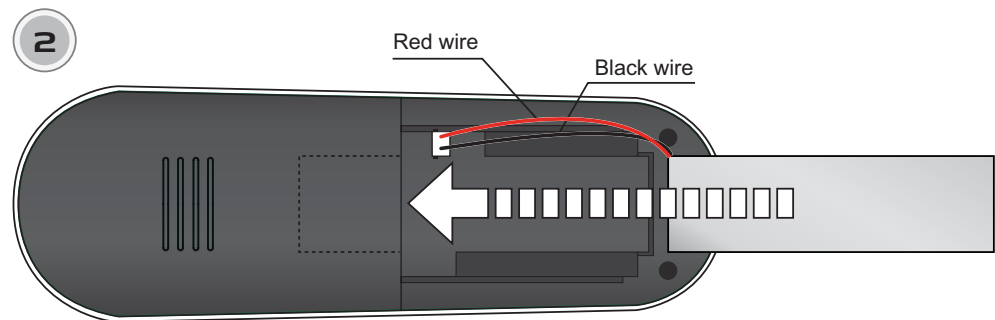

Remark: The battery unit characteristics label must be oriented towards the bottom.

- Put the battery unit hatch back in its place.

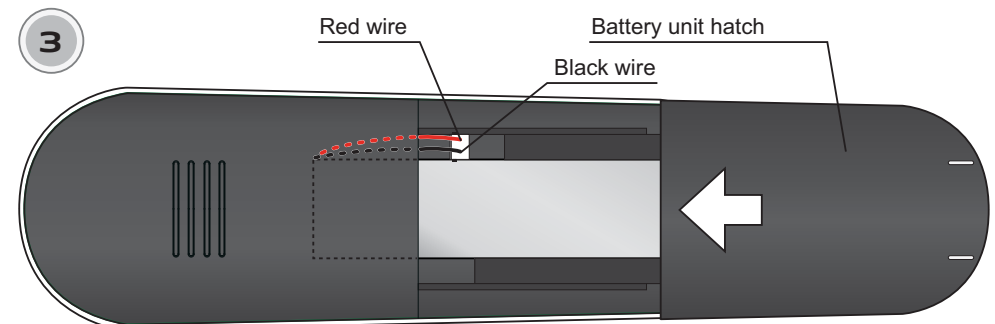

The used battery unit must be disposed of complying with the recycling instructions in the Environment paragraph of this booklet.

Only use rechargeable battery units NiMH 2.4V 600 mAh. On first use, to ensure maximum charging, leave the handset on the base unit for at least 12 hours. While charging, the battery may heat up. This is normal and presents no danger.

SET-UP

Battery function duration

The battery capacity should allow for approximately 120 hours on standby, 10 hours conversation.

Longevity of the battery

To maximise battery longevity, note the following:

- Do not short-circuit the plug.
- Use your handset as a mobile phone and do not replace it in the base station or charger (accessories) to be charged after every phone call.

Battery charging status

The battery charging status is displayed on the screen. The number of strokes show the battery charge status ("□" flat, "▣▣▣" charged). If the battery unit capacity is almost exhausted, the screen backlight is deactivated with a warning beep sounds. This sound is also produced when the battery unit is removed then put back in its place. As a rule, a new battery unit only reaches its maximum capacity after several charge/recharge cycles, even if the battery unit display shows that the battery unit of the handset is charged, you should take into account that the length of normal calls and availability time is limited at the beginning.

Switching the handset on and off

To switch on your handset press the »  « key.

To switch off the handset hold down the »  « key for a period. Your handset is then switched off.

Out of range

When the distance between the handset and the base is too great, the "Antenna"  signal flashes.
Move back towards the base unit

When the "Antenna"  symbol stops flashing the link with the base has been re-established.

BLOCK DIAGRAM

Phonebook	- New Entry
	- List Entry
	- Edit Entry
	- Delete Entry
	- Delete All

Set Date/Time

Personal Set	- Handset Tones	- Ring Volume
		- Ring Melody
	- Handset Name	
	- Auto answer	
	Auto hang-up	
	- Language	
	- Base Tone	- BS Ring Vol
		- BS Ring Mel

Advanced Set	- Recall Time
	- Registration
	- Unregister
	- Change PIN
	- Reset



Answ. Machine	- Play	
	- Record Memo	
	- Answ. Mode	
	- Ans. On/Off	
	- Settings	- Ring Delay
		- Remote access
		- HS Screening

MAKING TELEPHONE CALLS

Making an external call

External calls are calls made to the public network.

Enter the number of the person you are calling using the keypad and press the »« key. In the event of an error being made in entering a number, press the »**BACK**« key to delete the incorrect number.

If the person you are calling is recorded in the phonebook contact list, move the browser downwards ▼ »« key, select the name of the person you are calling then press the »« key.

Answering a call

when a call is received, every handset registered on the base unit will ring.

Press the »« key on one of the handsets to answer the call.

At the end of the conversation press the »« to hang up.

Making an internal call

Internal calls are calls between two handsets registered on the same base unit. Internal calls are not charged for by your operator.

Press the »**INT**« key, the numbers of handsets registered on the base unit will appear on the display. Enter the number corresponding to the handset that you wish to call.

At the end of the conversation press the »« key.

CLI (Caller Line ID) function

Before using the phone number transfer (CLI), please contact your provider to subscribe to Caller Line Identification. This will enable you to receive calls displaying the callers number.

There might be a special rate or a fee required for this function to be enabled.

If the caller's phone number is in the phone book, the name of the caller is displayed as well as the number.

If the caller has suppressed or not activated the CLI function, »Unknown« appears.

MAKING TELEPHONE CALLS

Managing calls whilst communication is underway

This function is available if your installation is made up of at least two handsets registered on the same base unit.

Transferring a call to another handset

This function allows you to transfer the call that is in progress to another handset registered on the same base unit.

Keep the »INT« pressed, the external call is put on hold, enter the number of the handset to which you wish to transfer the call.

When the handset being called is picked up, transfer the call by pressing the key symbol .

Remark: If the handset called does not answer, you can recover the call, Keep pressing the »INT« key.

Switching between an external and internal call

Keep the »INT« key pressed, the external call is put on hold, select the handset to which you want to transfer the call.

When the handset being called is picked up, keep the »INT« key pressed to switch between external/internal calls.

Setting up a three party conference call

Keep the »INT« pressed, the external call is put on hold, enter the number of the handset to which you wish to transfer the call.

When the handset being called is picked up, conference press and hold »*« key pressed.

You can revert to a communication between two parties for both internal and external calls. During a conference press and hold »INT« key pressed.

Call management

Receiving a second call

When you are on the phone, a sound beep is issued to let you know that another call is waiting. The screen displays the latter's name and number (depending on the operator).

Press the »R/C« keys +  to take this new call.

Caller #1 is put on hold and you can talk to Caller #2.

MAKING TELEPHONE CALLS

Issue of a second call

While you're on the phone, press the »R/C« key then dial the number to call.

To switch from one call to another

Press the »R/C« keys +  to switch from one call to another.

The current call goes on hold and you can then take the second call.

To finish one call and continue another

Press the »R/C« keys + .

The current call is terminated and you can then take the second call.

To make a conference call for 3 people (the 2 calls and you)

Press the »R/C« keys + .

You can then speak to both correspondents at once.

To terminate the 3-way conference call, press .



Locking the handset keypad

Keep the »*« key pressed until the »« icon is shown on the display.

To unlock the keypad keep the »*« key pressed until the »« icon disappears from the display.

Using in hands-free mode

Hands-free mode allows you to hold a dialogue with your caller without holding the handset. It also allows other persons present in the room to hear the conversation.

Press the »« key, the »« icon appears on the display. Dial the number of the person you are calling.

When a call is received, press the »« key. Hands-free mode is then activated.

MAKING TELEPHONE CALLS

Setting the volume

This function allows you to set the listening volume during a conversation.

Move the browser up ▲ or down ▼ to increase or reduce the listening volume. You can set the volume to a level from 1 to 5. The volume level selected is shown on the display.

Remark: This function is also available in hands-free mode.

Secret mode

This function enables you to activate or deactivate the handset microphone during a call. You can therefore allow your caller to hear or prevent your caller from hearing what you are saying.

Press the »⊗« key, the person on the line cannot then hear what you are saying.

To deactivate secret mode press the »⊗«, key. The person on the line can now hear what you are saying.

PHONEBOOK

You can store up to 200 contacts in your phonebook.

Each entry can contain the name of your contact as 10 characters (including spaces) and their telephone number as 20 numbers.

Adding a phonebook entry

You can enter names and call numbers manually or add contacts from the received or the outgoing call logs.

Manually adding a phonebook entry



Go to »Menu« / »Phonebook«.

Select »New Entry«. Enter the contact name and number using the keypad. Confirm using the »OK« key.

Enter the phone number using the keypad. Confirm using the »OK« key.

Confirm using the »OK« key.

Adding a phonebook entry using the call log

Access the calls list directly by pressing the  key or moving the browser upwards .

Press the »OK« key to select »Copy to Phbk«. Enter the name and press the »OK« key. The number of the contact is displayed on the screen. Confirm using the »OK« key.

Viewing a phonebook entry

This function allows you to view the data for your contact.

Go to »Menu« / »Phonebook« (you can access the Phonebook directly by moving the browser downwards ).

Select »List Entry«.

Select the contact you wish to consult then press the »OK« key twice.

The display will show the name and the number assigned to your contact.

PHONEBOOK

Editing a phonebook entry

The function allows you to modify the name, number and melody assigned to your contact.

Go to »Menu« / »Phonebook«.

Select »Edit Entry«.

Select the contact you wish to modify then press the »OK« key.

Use the »BACK« key to make changes.

Confirm using the »OK« key.

Deleting a phonebook entry

Go to »Menu« / »Phonebook«.

Select »Delete Entry«.

Select the contact you wish to delete then press the »OK« key.

Confirm using the »OK« key.

An audible tone shows that the phonebook entry is deleted from the list of contacts.

To cancel the deletion press the »BACK« key .

Deleting the entire phonebook

This function allows you to delete all the entries in your phonebook.

Go to »Menu« / »Phonebook« / »Delete All«.

Confirm using the »OK« key.

To cancel the deletion press the »BACK« key.

DATE AND TIME

Set the time and date

Go to »Menu« / »Set Date/Time«.

Enter the new time in the format Hours: minutes, then enter the new date in the format DD/MM. Press the »OK« key.

Remark: In the event of an error during entry, the last number can be edited by pressing the »BACK« key.

CUSTOMISATION

This menu enables you to customize your phone.

Setting the melody and handset volume for an external call

Go to »Menu« / »Personal Set« / »Handset Tones«.

Select »Ring Melody«, move the browser up ▲ or down ▼ to define the handset melody. Confirm the selection by pressing the »OK« key.

Select »Ring Volume«, move the browser up ▲ or down ▼ to adjust the handset melody volume. Confirm the selection by pressing the »OK« key.

Select »Key Beep«, move the browser up ▲ or down ▼ to activate/deactivate the beep keys. Confirm the selection by pressing the »OK« key.

Customising the name of the handset

This function allows you to assign a name to your handset (Max 12 characters).

Go to »Menu« / »Personal Set« / »Handset Name«.

Enter the handset name, confirm using the »OK« key.

Activating/deactivating automatic pick-up

Automatic pick-up when activated enables automatic pick-up as soon as the handset is removed from its base unit.

Got to »Menu« / »Personal Set« / »Auto answer«.

Move the browser up ▲ or down ▼ to activate/deactivate automatic pick-up, press the »OK« key.

Activating/deactivating automatic Hang-up

When automatic pick-up is activated, it enables automatic hang-up when you replace the handset on the base unit.

Got to »Menu« / »Personal Set« / »Auto hang-up«.

Move the browser up ▲ or down ▼ to activate/deactivate automatic hang-up, press the »OK« key.

CUSTOMISATION

Setting the menu language

This function allows you to change the language in which the displays are shown.

Go to »Menu« / »Advanced Set« / »Language«.

Select the desired language by moving the browser up ▲ or down ▼ and pressing »OK«.

Setting the base unit melody and volume

Go to »Menu« / »Personal Set« / »Base Tone«.

Select »BS Ring Mel« and move the browser up ▲ or down ▼ to choose the base unit melody. Confirm the selection by pressing the »OK« key.

Select »BS Ring Vol« and move the browser up ▲ or down ▼ to adjust the melody volume. Confirm the selection by pressing the »OK« key.

ADVANCED SETTINGS

This function allows you to set the functions relating to the handset.

- Recall Time
- Registration
- Unregister
- Change PIN.
- Reset

Setting the flash time

If you connect your telephone to an automatic PBX or in a foreign country, you may need to change the flash time in order to use your telephone correctly for the following functions: call hold, three party conference calls.

Contact your operator to provide you with the appropriate duration and carry out a new setting operation.

Go to »Menu« / »Advanced Set« / »Recall Time«.

Select the flash time by moving the browser up ▲ or down ▼.

Press the »OK« key to confirm the selection.

Registering a new handset

You can register up to five handsets on your base unit. It will then be possible for you to make calls between handsets.

Remark: Calls between handsets are only possible when handsets are registered on the same base unit.
calls between handsets (internal) are not charged by the operator.

Keep the paging key of the base unit pressed until an audible signal is heard.

Go to »Menu« / »Advanced Set« / »Registration«.

Enter the PIN code (Personal Identification Number), factory setting: 0000).

Press »OK« to register the handset on the base unit.

To cancel the handset registration, press the »BACK« key.

Once registration is complete, the handsets will display the available handset number (between 1 and 5).

ADVANCED SETTINGS

You can select the number that you want to be associated by pressing the corresponding numbered key (press key 1 to select handset number 1).

Removing a handset

This function allows you to remove a handset from your base unit. This may be necessary if a handset is lost or if you already have 5 handsets assigned to the base unit.

Go to »Menu« / »Advanced Set« / »Unregister«.

Enter the PIN code (Personal Identification Number, factory setting : 0000).

Press »OK«.

the numbers of the handsets registered on the base unit appear on the display.

Enter the number of the handset that you wish to remove.

The removed handset will show "**Non-Subscription**" until it is registered once again.

Changing your PIN code

This function is used to protect your settings against unauthorised access; you can assign a personal identification PIN number (0000 factory default setting).

Remark: Ensure that you remember the PIN number; it will be required should you wish to change certain settings.

Go to »Menu« / »Advanced Set« / »Change PIN«.

Enter the new PIN, confirm using the »OK« key.

Enter the new PIN once more, confirm using the »OK« key.

Remark: In the event of an error during entry the last number can be deleted by pressing the »BACK« key.

ADVANCED SETTINGS

Resetting the handset and the base unit default settings

The reset function is used to return to factory default settings. It deletes the contacts in the phonebook and from the call list.

Go to »Menu« / »Advanced Set« / »Reset«

Enter the PIN code (Personal Identification Number, factory setting : 0000). Press the »OK«.

Press the »OK« key to confirm the reset.



To cancel the reset press the »« key.

CALL LOG

The list of calls made by your telephone can contain 10 records made up of a number with a maximum of 24 figures and a name with a maximum of 10 characters.



The list of calls received by your telephone can contain 20 records made up of a number with a maximum of 24 figures and a name with a maximum of 12 characters.

To display the list of calls made

Press the »« key or move the browser up ▲ () to display the list of dialled or received numbers.

Select the number that you wish to call again; press the the »«. The number is dialled automatically.

Removing numbers from the list of calls



Press the »« key or move the browser up ▲ () to display the list of dialled or received numbers.

Press »OK«, Select »Delete« or »Delete All« by moving the browser up ▲ or down ▼ .

Press the »OK« key to confirm deletion.

Press the »BACK« key to cancel deletion.

Storing a caller's details in the phonebook

Press the »« key or move the browser up ▲ () to display the list of dialled or received numbers.

Select the number that you wish to store.

Press the »OK« key to select »Copy to Phbk«. Enter the name and press the »OK« key. The number of the contact is displayed on the screen. Confirm using the »OK« key.

ANSWERING MACHINE (D77V only)

This telephone is equipped with an integral digital answering machine with a recording capacity of **14** minutes. Announcement messages (ANNOUNCEMENT 1 + 2) can last 1 minute each.

Go to »Menu« / »Answ. Machine«.

The following Functions appear on the display:

- Play
- Record Memo
- Answ. Mode
- Ans. On/Off
- Settings

Playing a message

Go to »Menu« / »Answ. Machine« / »Play«.

Press »OK« to play messages. New messages are played first.

Press the »Menu« key to access the various options relating to messages. The list of options is shown on the display.

- Repeat
- Delete All
- Delete
- Prev. Message
- Next Message

Press the »BACK« key to exit the menu.

If there are no messages, the handset shows "**No message**".

Remark : Long press on key **5**, from the standby screen, starts reading the messages directly (see the paragraph "Rapid access to the answering machine messages", page 11).

Remark : If your answering machine is full, the answering machine moves to simple mode and the base unit display flashes alternately between **88** and the number of messages.

ANSWERING MACHINE

Recording a memo

This function allows you to place a personal message on your answering machine. Whilst it will not be heard, it will be regarded as a new message by the answering machine.

Go to »Menu« / »Answ. Machine« / »Record Memo«.

Press »OK« to switch to memo record mode; the heading »Memo« is shown on the display.

Press the »BACK« key to return to the previous menu.

Press the »OK« key to interrupt recording.

Selecting answer machine mode

Go to »Menu« / »Answ. Machine« / »Answ. Mode.«.

Select answer machine mode by moving the browser up ▲ or down ▼.

- **Recorder** : To activate the answering machine recorder.
- **Answer only.** : To activate the answering machine only.

The announcement to be used will be played.

Selecting an outgoing message

Go to »Menu« / »Answ. Machine« / »Answ. Mode«.

Select the announcement mode you wish to personalize by moving the browser up ▲ or down ▼.

Press »OK« key.

- **Personalized** : selects the personalized announcement of the answering machine mode (simple or recorder).
- **Predefined** : selects the predefined announcement of the answering machine mode (simple or recorder).

Recording an outgoing message

This function is used to customise the outgoing messages from your answering machine.

Go to »Menu« / »Answ. Machine« / »Answ. Mode«.

Select the announcement mode you wish to personalize by moving the browser up ▲ or down ▼.

ANSWERING MACHINE

Press »OK« key.

Select »Personalized« by moving the browser up ▲ or down ▼ .

Press »OK« key.

Select »Record mess.« by moving the browser up ▲ or down ▼ .

Press the »OK« key to start the recording.

Press the »OK« key to stop the recording.

Press the »BACK« key to return to the previous menu.

Once the recording is complete, the announcement plays automatically.

Playing back an outgoing message

This function is used to play back your answering machine's outgoing message.

Go to »Menu« / »Answ. Machine« / »Answ. Mode«.

Select the announcement you wish to listen to again by moving the browser up ▲ or down ▼ .

Press »OK« key.

Select »Personalized« by moving the browser up ▲ or down ▼ .

Press »OK« key.

Select »Play message« by moving the browser up ▲ or down ▼ .

Press the »OK« key to start reading.

Press the »BACK« key to return to the previous menu.

ANSWERING MACHINE

Activating/deactivating the answering machine

This function is used to activate or deactivate your answering machine.

Go to »Menu« / »Answ. Machine« / »Ans. On/Off«.

Press the »OK« key to display the answering machine status.

Select »On« / »Off« by moving the browser up ▲ or down ▼ .

Press the »OK« key to confirm.

TAM Settings

This menu allows you to change advanced settings on your answering machine (according to model).

Go to »Menu« / »Answ. Machine« / »Settings«.

The following functions appear on the display:

- Ring Delay
- Remote access
- HS Screening

Delay before the answering machine answers the call

This setting is used to specify the number of times your telephone rings before your answering machine answers the call. The number of rings can be between 3 and 8 and you can also select Automatic mode.

Automatic mode will automatically determine the number of rings, depending on the number of messages stored in the answering machine.

Go to »Menu« / »Answ. Machine« / »Settings« / »Ring Delay«.

Select the number of rings by moving the browser up ▲ or down ▼ .

Automatic: if you select "**Automatic**", the answering machine will answer the call after the second ring if a new message has been recorded. Otherwise it answers after four rings. Users can therefore determine whether or not a new message has been recorded from the number of rings.

3~8 rings: users can also programme the number of rings before the answering machine switches on (the default setting is 5 rings).

ANSWERING MACHINE

Call filtering

When activated the filtering function allows you to monitor the message being left by the caller as it is being recorded. You can pick up the phone to take the call at any time.

Go to »Menu« / »Answ. Machine« / »Settings« / »Remote access«.

Press the »ON« / »OFF« key to activate/deactivate the Remote access function.

To filter incoming calls you can allow callers to start recording their message (in order to identify the caller), then pick up the handset or press the »« key to take the call.

If call filtering is activated, the message recorded by the caller will be audible; if call filtering is deactivated the message will not be audible.

The answering machine automatically interrupts recording when you pick up the handset.

Remark : Filtering only works with handset number 1 (see the paragraph "Screen", page 11).

Remote control

You can play back your answering machine in remote mode. This function allows you to recover your messages and access your answering machine from any other telephone located outside your place of residence.

General management

When the answering machine is deactivated and remote control is deactivated, the equipment does not answer any calls and remote access is not possible. The base unit display is switched off.

If the answering machine is deactivated and remote control is active, the equipment answers a call after 10 rings by playing the following message: "**Enter PIN**".

In this mode you can remotely activate your answering machine. Once activated the telephone is in answering machine/recording mode, the equipment uses the operating mode already selected by the user.

ANSWERING MACHINE

Activating/deactivating remote control

Go to »Menu« / »Answ. Machine« / »Settings« / »HS Screening«.

Select »On« / »Off« by moving the browser up ▲ or down ▼ to activate or deactivate remote control.

Press the »BACK« key to return to the previous menu.

Remote control operation

When remote control and the answering machine are both activated, enter the PIN code when the outgoing message is being played back in order to access the answering machine. A long audible confirmation signal is heard telling you that the connection has been established.

The remote interrogation code corresponds to the base unit PIN code (see "Changing your PIN code", page 26.).

Remote control operation is described in the following section.

- If you do not press a key within 10 seconds, the machine automatically stops.
- The code is detected during the playback of the outgoing message.
- After three attempts at entering an incorrect PIN the telephone terminates the session and hangs up.
- The maximum delay between two numbers is 4 seconds.
- The telephone receives commands whilst messages, memo and the outgoing message are being read.

ANSWERING MACHINE

Remote access key functions

Playing messages and memos	
Key sequences	Answering machine function
2	Play all messages
*2	Play new message only
5	Pause
2	Repeat play back
55	Stop play back
1	Return to the start of the message
11	Go to the previous message
3	Go to the next message

Deleting messages and memos	
Key sequences	Answering machine function
02	Delete a single message, whilst it is being played
02 (After all messages were played)	Delete all messages played after playback

Recording outgoing messages	
Key sequences	Answering machine function
61	Recording a personalized message for the answering machine recorder.
62	Recording a personalized message for the answering machine only.

ANSWERING MACHINE

Playing back outgoing messages	
Key sequences	Answering machine function
71	Reading the announcement currently used for the answering machine recorder.
72	Reading the announcement currently used for the answering machine only.

Recording memos	
Key sequences	Answering machine function
63	Start recording a MEMO
5	Stop recording

Setting up the answering machine	
Key sequences	Answering machine function
8	Activating the answering machine recorder/ Activating the answering machine only/ Deactivating the answering machine.

TECHNICAL DATA

Condition on delivery

Base:

Ring volume:	Low
Ring melody:	3
PIN:	0000
Interval:	On
Flash time:	Medium

Handset:

Ring volume:	High
Ring melody:	5
Handset volume:	2
Keypad tone:	On
Display language:	English
Automatic pick-up:	Off
Automatic Hang-up:	Off
Telephone book:	Empty
Call list:	Empty
Redial:	Empty

Answering machine (D77V only):

TAD-PIN remote message

enquiry:	PIN (0000)
Answering machine:	On (recorder)
Texts:	1 message text and 1 announcement text

TECHNICAL DATA

Features

Standard	DECT, GAP
Frequency range	1880-1900 MHz
Transmission channels	1
Medium output Approx. Range	20 10 mW Up to 300 m outdoors Up to 50 m indoors
Power supply:	
Power supply unit	230 V, 50 Hz, 40 mA
Battery bloc	Type Ni-MH, 2,4 V 600 mAh
Dialling method	DTMF (touch tone)
Handset operating life:	
In use	Up to 12 hours*
In standby	Up to 120 hours*
Ambient temperature	+5 °C to +45 °C
Dimensions:	
Base station (L x W x H)	130 mm x 121mm x 43mm
Handset (L x W x H)	46mm x 146mm x 23mm
Weight:	
Base station	110 gr.
Handset	110 gr.
Answering machine:	Approx. 14 minutes Length of recording (D77V only)

* If the base station is not connected to the mains (such as in a power outage), the handset continuously searches for a base station.

Technical changes and errors reserved.

WARRANTY

Terms and Conditions for United Kingdom & Ireland only

In order to apply the guarantee, you should contact the SAGEMCOM Helpdesk or the retailer where you purchased the equipment. Proof of purchase will be required in either case. Please make sure that you use your equipment only for the purpose for which it was designed and under normal usage conditions.

SAGEMCOM do not accept any liability for the equipment if used outside the frame of its original designed purpose or any consequence that may arise from this usage.

Should any malfunction arise, the SAGEMCOM Helpdesk or your retailer will advise you how to proceed.

A) General Guarantee conditions

SAGEMCOM undertakes to remedy by repair or exchange at its own convenience, free of charge for labour and replacement parts, any defects in the equipment during the guarantee period of 12 (twelve) months or 3 (three) months for accessories, from the date of original invoice of the Equipment, where those defects are a result of faulty workmanship.

Unless the customer has concluded with SAGEMCOM a maintenance contract in respect of the equipment which specifically provides for repairs to be carried out at the customer's premises, the repairs will not be carried out on the equipment at the customer premises.

The customer must however return the defective equipment at his/her own expense, to the address supplied by the SAGEMCOM Helpdesk or by the retailer.

In the case that a product needs to be sent in for a repair, it must always be accompanied by a proof of purchase (which is not altered, written on or in any way made illegible) showing that the product is still under guarantee. In the case that no proof of purchase is enclosed, the SAGEMCOM repair centre will use the production date as its reference for establishing the guarantee status of the product.

Apart from all legal obligatory rules, SAGEMCOM, do not give any Guarantee, either implicit or explicit which is not set force in the present section, and can not be held responsible for any direct or indirect, material or immaterial damage, either in or out of the frame of the present guarantee.

WARRANTY

If any provision of this guarantee shall be held to be in whole or in part invalid or illegal due to an obligatory rule applicable to consumers pursuant to their national legislation, such invalidity or illegality shall not impair or affect the remaining provisions or parts of this guarantee.

This guarantee does not affect the Customer statutory rights.

B) Exclusions From Guarantee

SAGEMCOM shall have no liability under the guarantee in respect of:

- Damage, defects, breakdown or malfunction due to one or more of the following:
 - Failure to properly follow the installation process and instructions for use
 - An external cause to the equipment (including but not limited to: lightning, fire, shock, vandalism, inappropriate conditions of electrical network or water damage of any nature)
 - Modifications made without the written approval of SAGEMCOM
 - Unsuitable operating conditions, particularly of temperature and humidity
 - Repair or maintenance of the equipment by persons not authorised by SAGEMCOM
- Wear and tear from normal daily use of the equipment and its accessories
- Damage due to insufficient or bad packaging of equipment when returned to SAGEMCOM
- Usage of new versions of software without the previous approval of SAGEMCOM
- Work on any equipment or software modified or added without the prior written consent of SAGEMCOM
- Malfunctions not resulting from the Equipment or from software installed in user workstations for the purpose of use of the equipment.

Communication problems related to an unsuitable environment including:

- Problems related to access and/or connection to the Internet such as interruptions by access networks or malfunction of the line used by the subscriber or his correspondent
- Transmission faults (for example poor geographical coverage by radio and TV transmitters, interference or poor line quality)

WARRANTY

- Local network faults (wiring, servers, workstations) or the failure of the transmission network (such as but not limited to interferences, fault or poor quality of the network)
- Modification of the parameters of the cellular or broadcast network carried out after the sale of the Product
- Normal servicing (as defined in the user guide supplied with the equipment) as well as malfunctioning due to servicing not being carried out. Servicing costs are in any event always borne by the customer.
- Malfunctions resulting from the usage of products, consumables or accessories not compatible with the equipment.

C) Out of Guarantee Repairs

In the cases set forth in B) as well as after expiry of the guarantee period, the customer must ask the Authorised SAGEMCOM Repair Centre for a cost estimation prior to work being carried out.

In such cases, the repair and delivery costs will be invoiced to the customer.

The foregoing shall apply unless otherwise agreed in writing with the customer and only for the United Kingdom and Ireland.

SAGEMCOM Helpdesk (from UK) : 08 45 09 00 316

SAGEMCOM Helpdesk (from Ireland) : 01 60 583 84

SAGEMCOM Helpdesk Email :

dti.faxservice-uk@sagemcom.com

WARRANTY

Terms and Conditions for other countries

If, despite our best efforts, your product presents any defects, you should refer to your retailer and present the proof of purchase that they gave you on the day of purchase.

Should any malfunctioning arise, the retailer will advise you what to do.

For the warranty to apply, you should ensure that the product was used in accordance with the instructions for use and the purpose for use, and that you have at your disposal the sales invoice or receipt stating the date of purchase, the name of the retailer, the reference and the serial number of the product.

No coverage shall be given under this warranty if the following conditions are applicable:

- The required documents have been modified or altered in order to take advantage of the warranty.
- The manufacturing numbers, product brands or labels have been altered or made illegible.
- Interventions on the product have been made by an unauthorized person.
- The product has been subjected to abnormal or improper use.
- The product has been damaged by external factors such as lightning, over-voltage, moisture, accidental damage, improper care as well as all Acts of God.

This present warranty does not affect the consumer rights that you may have under the laws in effect in your country.

Important:

Should you return the product to the after-sales department, please ensure that you return as well all the elements and accessories originally supplied with the product.

User Manual
Data subject to change without notice



SAGEMCOM SAS

Société par actions simplifiée au capital de 158.291.895 € - 440 294 510 RCS PARIS
250, route de l'Empereur - 92500 Reuil-Malmaison - France
www.sagemcom.com